

Part Number: PT478 18130

Kit Contents

Item #	Quantity Req'd.	Description
1	1	LH Bracket
2	1	RH Bracket
3	1	LH Extrusion
4	1	RH Extrusion
5	1	Slide Assembly
6	4	4.0mm PT (Torx) Screws
7	1	Armrest Top
8	1	Armrest Base

Hardware Bag Contents

Item #	Quantity Req'd.	Description
1	1	Installation Template
2	10	4.8mm Al Pop Rivets
3	2	Plastic Retainer Clip

Additional Items Required For Installation

Item #	Quantity Req'd.	Description
1		

Conflicts

--

Recommended Tools

Personal & Vehicle Protection	Notes
Safety Glasses	
Special Tools	Notes
Installation Tools	Notes
Masking Tape	
Scissors	
Center Punch	<i>Spring Loaded</i>
Drill Bits	3.0(1/8"), 5.0(13/64"), 8.0 (5/16")
Drill Stop	8.0 (5/16")
Power Drill	
Tape Measure	<i>Metric</i>
Pop Rivet Tool	
Torque Wrench	2.0 Nm (18 in-lbf)
TORX Screwdriver	T-20
Special Chemicals	Notes

General Applicability

Center Armrest can be installed on all Scion FR-S Models
--

Recommended Sequence of Application







Item #	Accessory
1	

*Mandatory

Vehicle Service Parts (may be required for reassembly)

Item #	Quantity Req'd.	Description
1		
2		
3		

Legend

	STOP: Damage to the vehicle may occur. Do not proceed until process has been complied with.
	OPERATOR SAFETY: Use caution to avoid risk of injury.
	CAUTION: A process that must be carefully observed in order to reduce the risk of damage to the accessory/vehicle and to ensure a quality installation.
	TOOLS & EQUIPMENT: Used in Figures calls out the specific tools and equipment recommended for this process.
	REVISION MARK: This mark highlights a change in installation with respect to previous issue.
	SAFETY TORQUE: This mark indicates that torque is related to safety.

Care must be taken when installing this accessory to ensure damage does not occur to the vehicle. The installation of this accessory should follow approved guidelines to ensure a quality installation.

These guidelines can be found in the "Accessory Installation Practices" document.

This document covers such items as:-

- Vehicle Protection (use of covers and blankets, cleaning chemicals, etc.).
- Safety (eye protection, rechecking torque procedure, etc.).
- Vehicle Disassembly/Reassembly (panel removal, part storage, etc.).

Please see your Toyota dealer for a copy of this document.

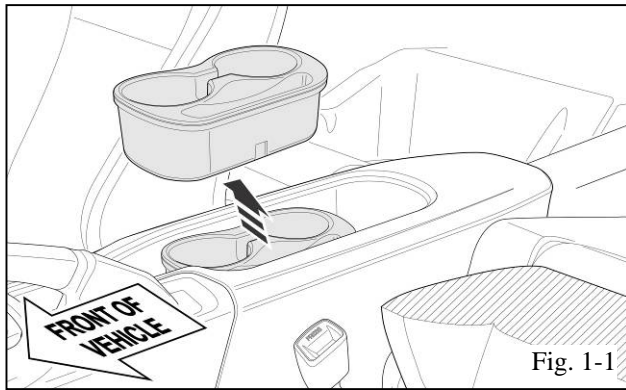

1. Vehicle Preparation.

- (a) Remove the OE center console cup holder (Fig. 1-1).
- (b) Remove the rubber liner from the bottom of the center console.
- (c) If necessary, clean the top surface of the center console with soap and water.

2. Mounting Bracket Installation.

- (a) Cut out paper Template A.
- (b) Install Template A on the center console.
 - (1) Use the markings on Template A to properly align it to the bottom of the center console (Fig. 2-1).
 - (2) Secure Template A with masking tape (Fig. 2-1).



ATTENTION: Confirm that the template is properly aligned before moving to the next step.

- (c) Drill the holes indicated on the template.
 - (1) Center punch the 2x hole locations indicated on Template A (Fig. 2-2).
 - (2) Remove Template A and drill the 2x center punched locations with a 3.0mm (1/8") drill bit. Enlarge these 2x holes to 5.0mm (13/64").

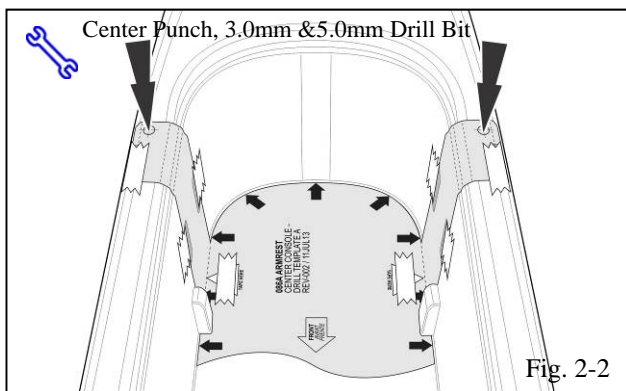
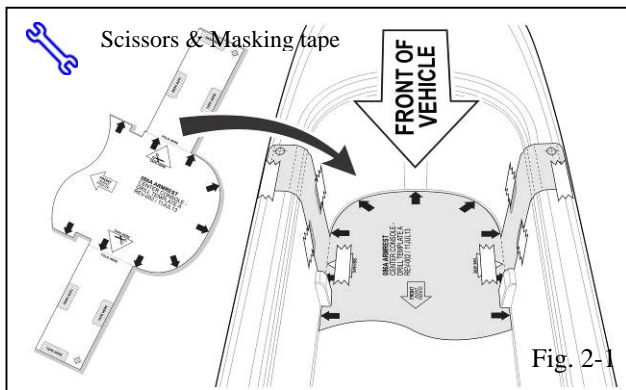

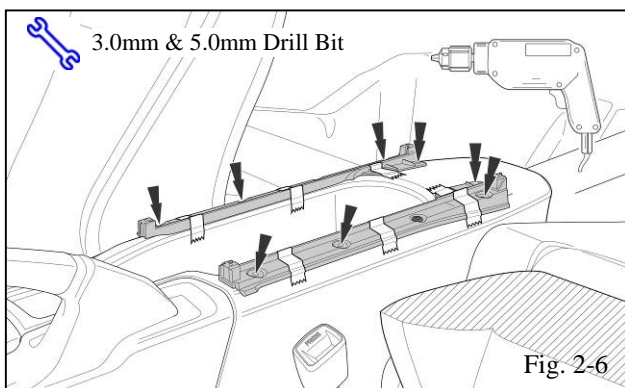
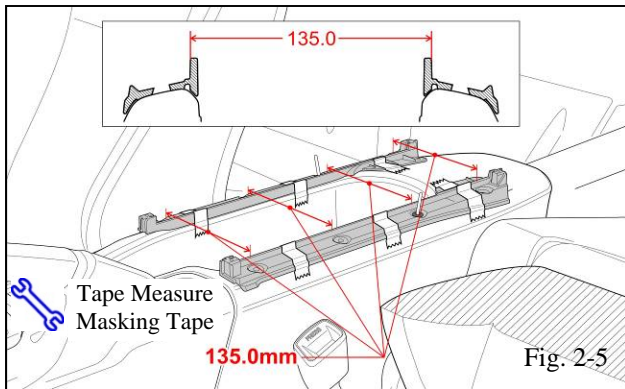
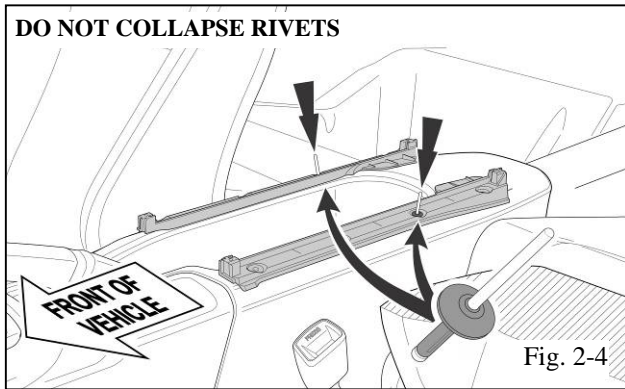
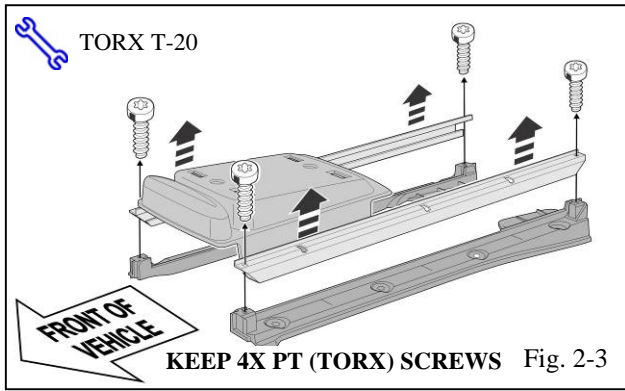

(d) The LH and RH brackets are assembled to the armrest slide / extrusion assembly for shipping. **While working at a table or bench**, separate the brackets from this assembly by removing 4x PT (Torx) screws. **Retain the 4x PT (Torx) screws for assembly** (Fig. 2-3).

(e) Fit the LH and RH brackets onto the center console.

(1) For each bracket, align the 3rd hole from the front of the bracket with the holes drilled in Step 2(c)(2) (Fig. 2-4).

(2) Insert a 4.8 aluminum pop rivet into each location. **DO NOT COLLAPSE THE RIVETS AT THIS TIME** (Fig. 2-4).

(f) Confirm the alignment of the LH and RH brackets.

(1) Starting from the front hole location moving rearward, measure the gap between the brackets. Adjust the brackets so that all measurements are 135mm (Fig. 2-5).

(2) Once each dimension is confirmed, hold the brackets in place with masking tape.

ATTENTION: Confirm the brackets are the correct distance apart before moving to the next step.

(g) Mount the LH and RH brackets to the center console.

(1) Collapse the 2x 4.8 aluminum pop rivets installed in Step 2(e)(2).

(2) Drill a 5.0mm (13/64") hole in the center of each of the remaining 8x bracket hole locations (Fig. 2-6).

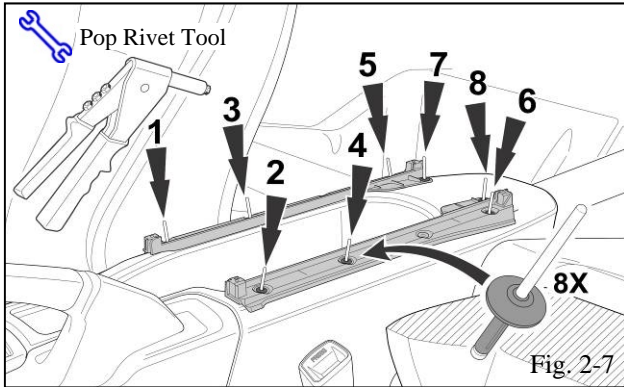

- (3) Insert the 8x remaining 4.8 aluminum pop rivets into the LH and RH brackets (Fig. 2-7).
- (4) Starting from the front moving rearward, collapse each LH and RH pair of pop rivets, following the order shown; 1 through 8. Confirm the distance between the brackets as you go (Fig. 2-7).
- (5) Remove the masking tape.

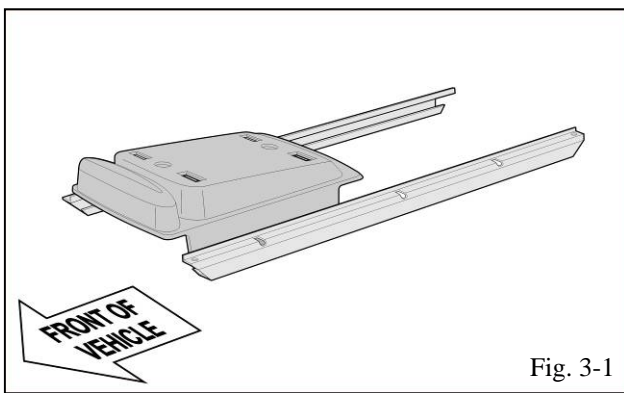

3. Install the Armrest Slide Assembly.



Refer to Fig. 3-1 to confirm the correct orientation of the armrest slide / extrusion assembly before continuing.

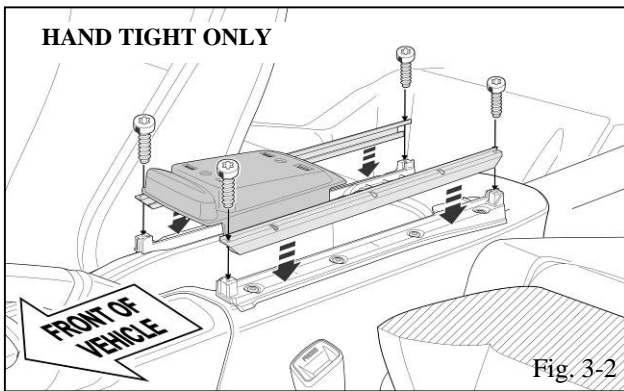

- (a) Align the armrest slide / extrusion assembly onto the LH and RH brackets installed in Step 2 (Fig. 3-2).
- (b) Secure the armrest slide / extrusion assembly to the brackets.

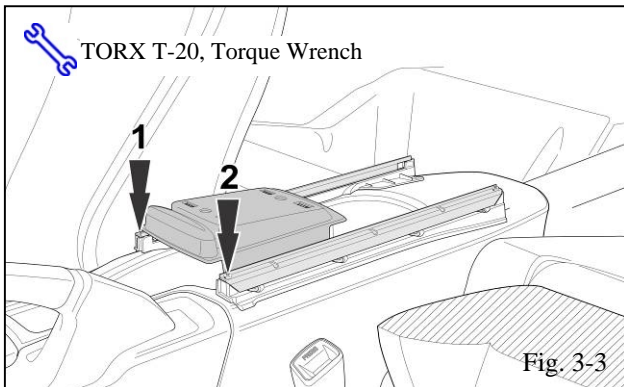

- (1) Insert the 4x PT (Torx) screws through the holes on the ends of the extrusions and into the brackets. **HAND TIGHTEN ONLY, DO NOT TORQUE.**
- (2) Slide the armrest slide assembly to the forward position. Tighten the 2x front PT (Torx) screws to 2.0Nm (18 in-lbf) (Fig. 3-3).

2.0 Nm (18 in-lbf)

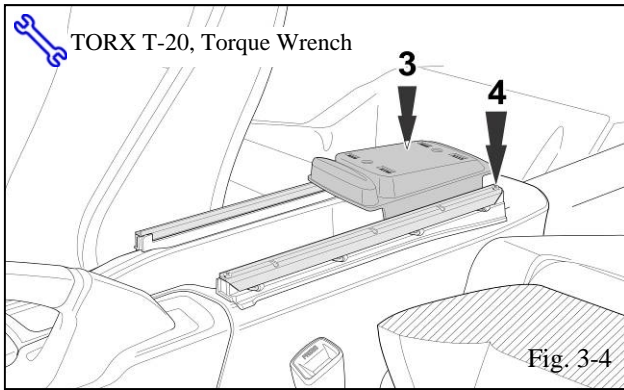

- (3) Slide the armrest slide assembly to the rearward position. Tighten the 2x front PT (Torx) screws to 2.0Nm (18 in-lbf) (Fig. 3-4).

2.0 Nm (18 in-lbf)

- (e) Confirm the armrest slide assembly moves freely without binding-up or jamming. Also, confirm that the springs on the armrest slide engage into each of the 3 ‘Stop’ locations on the extrusions.



ATTENTION: If sliding action does not work, it may be necessary to loosen the 4x PT (Torx) screws and adjust the extrusions.

4. Drill the bezel mounting holes.

- (a) Cut out paper Template B.
- (b) Install Template B onto the center console.
 - (1) Use the markings on Template B to properly align it to the LH and RH brackets (Fig. 4-1).
 - (2) Secure Template B to the center console with masking tape (Fig. 4-1).

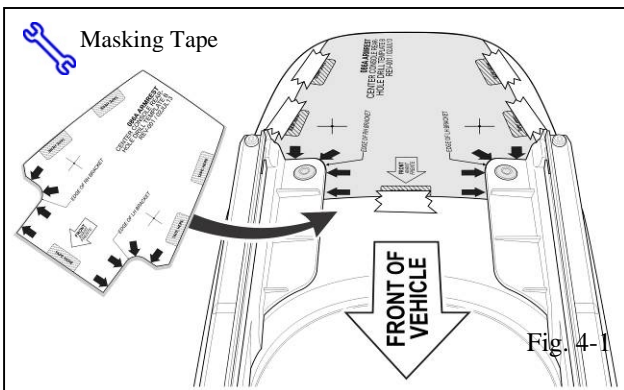

- (c) Center punch the 2x hole locations indicated on the template (Fig. 4-2).
- (d) Drill the 2x center punch locations with a 3.0mm (1/8”) drill bit (Fig. 4-2).
- (e) Remove the template and enlarge the 2x 3.0mm (1/8”) pilot holes to 8.0mm (5/16”) with a drill stop set at 50mm (2.0”).

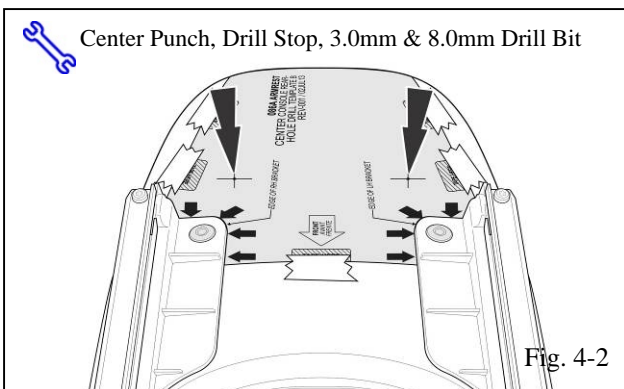

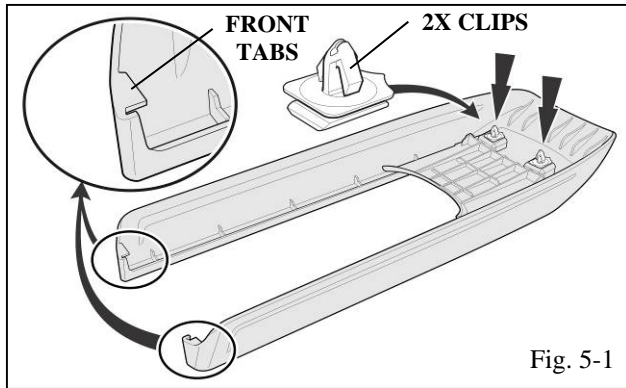

5. Install the Armrest Base and Armrest Top.

- (a) Install 2x plastic retainer clips into the ‘dog house’ features on the underside of the armrest base. Note the clip orientation (Fig 5-1).

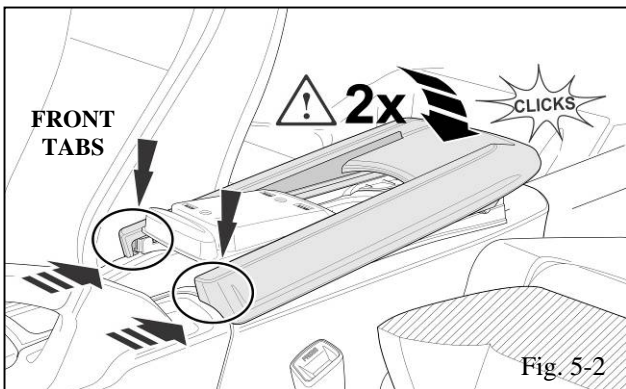

- (b) With the slide assembly in the forward position, install the armrest base onto the bracket / slide assembly.



- (1) Slide the 2x ‘Front Tabs’ of the armrest base underneath the front-bottom edge of the LH and RH brackets (Fig. 5-2).
- (2) Lower the rear portion of the armrest base down onto the center console aligning the 2x plastic retainer clips into the holes drilled in Step 4(e). Listen for the 2x CLICKS to confirm the retainer clips have engaged (Fig. 5-2).

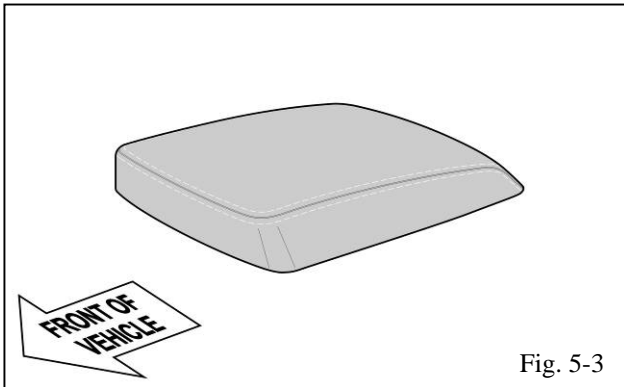

(c) Install the armrest top onto the armrest slide assembly:



Refer to Fig. 5-3 to confirm the correct orientation of the armrest top before continuing.

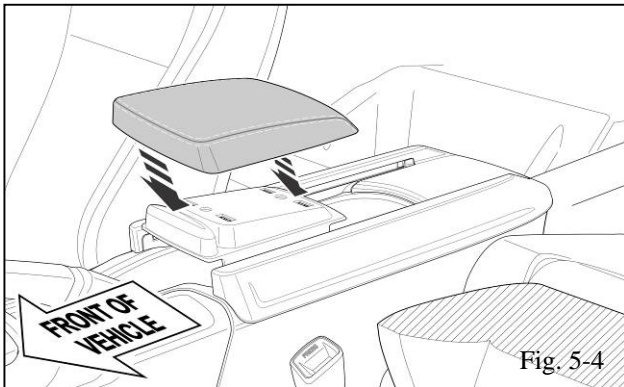

(1) Align the 2x molded pins and 4x barbed tabs on the underside of the armrest top into the holes on the armrest slide (Fig. 5-4).

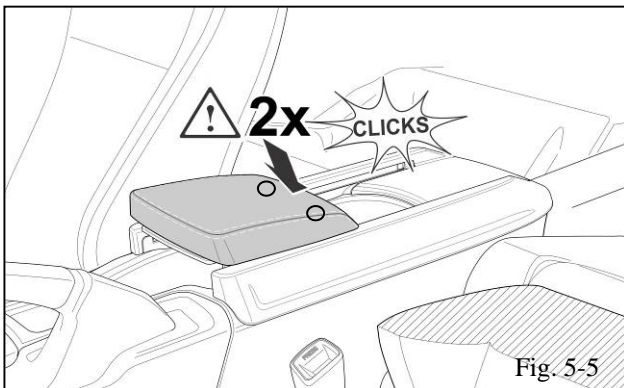

(2) Push down on the rear of the armrest top to ensure that the rear 2x barbed tabs engage first (Fig. 5-5).

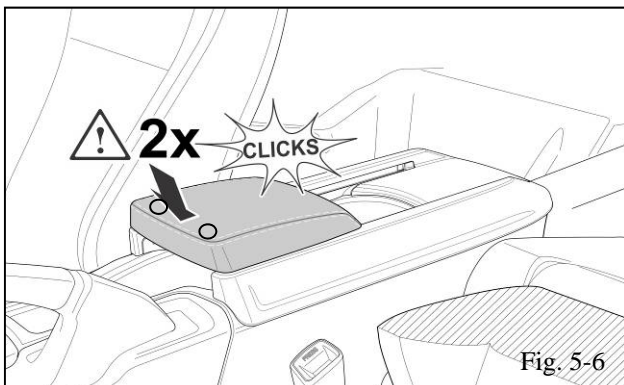

(3) Next push down on the front of the armrest top to engage the front 2x barbed tabs (Fig. 5-6).

(4) Confirm that all 4x barbed tabs have properly engaged.

- (d) Confirm that the armrest top / slide assembly moves freely without binding-up or jamming and that it engages into each of the 3x 'Stop' locations: Forward, Mid, and Rear.

6. Center Armrest Installation Complete.

- (a) Remove all plastic drill shavings from the center console's bin area.
- (b) Re-install the rubber liner from the bottom of the OE center console.
- (c) Re-install the OE center console cup holder (Fig. 6-1).
- (d) If necessary, vacuum the vehicle's interior to remove any plastic drill shavings.

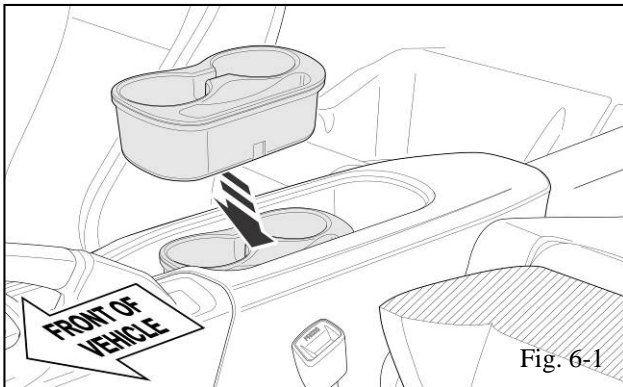

Checklist - these points **MUST** be checked to ensure a quality installation.

<u>Check:</u>	<u>Look For:</u>
<u>Accessory Function Checks</u> <input type="checkbox"/> Confirm that the armrest top / slide assembly functions.	<input type="checkbox"/> Ensure the armrest top moves freely without binding-up or jamming and that it engages into each of the 3x 'Stop' locations: Forward, Middle, Rear.
<u>Vehicle Function Checks</u> <input type="checkbox"/> <input type="checkbox"/>	
<u>Vehicle Appearance Check</u> <input type="checkbox"/> After accessory installation and removal of protective cover(s), perform a visual inspection.	<input type="checkbox"/> Ensure no damage (including scuffs and scratches) was caused during the installation process.